

HOUSING + STRAIGHT FEMALE PLUG

CRIMP TYPE 5/50S CABLE PACK500

R197.114.K01

Series : **SMB**
CARLOCK

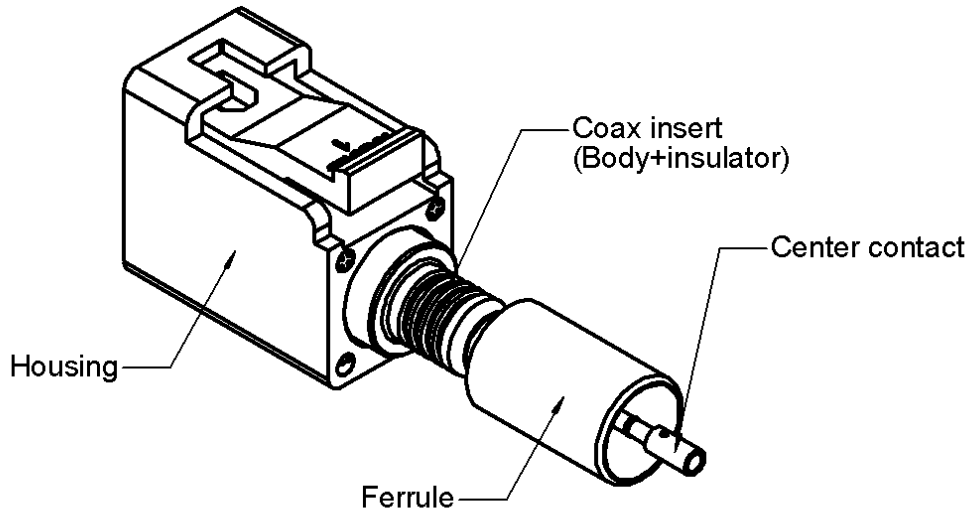
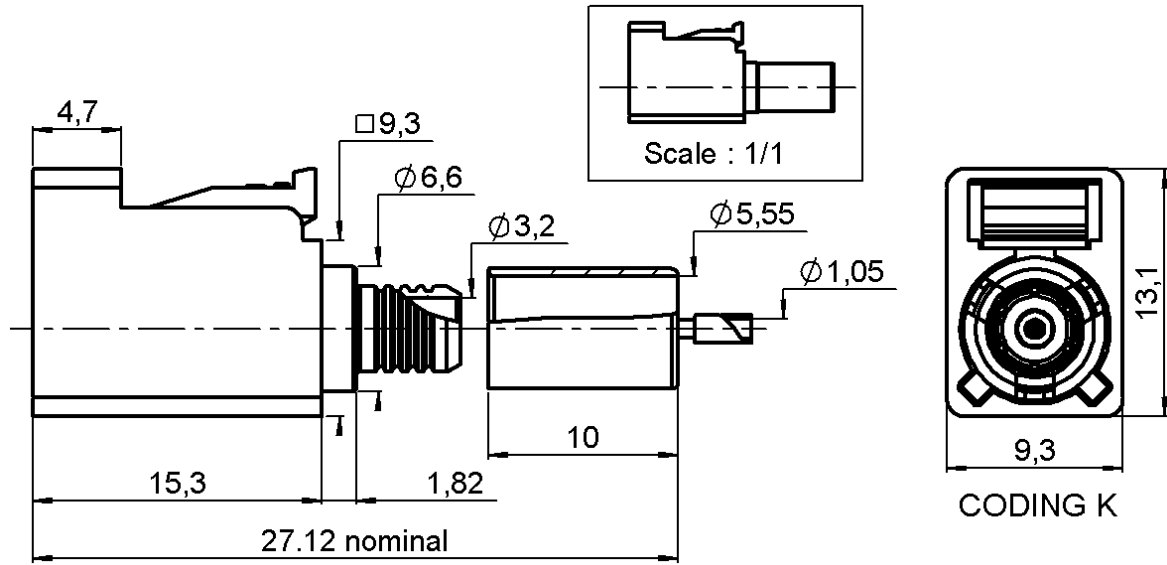

All dimensions are in mm.

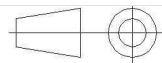

COMPONENTS	MATERIALS	PLATINGS (µm)
BODY	BRONZE	NICKEL 2
CENTER CONTACT	BRONZE	GOLD 0.8 OVER NICKEL 2
OUTER CONTACT	-	-
INSULATOR	PTFE	
GASKET	-	
OTHERS PARTS	BRASS	NICKEL 2
HOUSING	PA6.6 GF13 (POLYAMIDE)	UL CLASSIFICATION COLOR
		UL 94 V-2 CURRY RAL 1027

Issue : 0737 B

In the effort to improve our products, we reserve the right to make changes judged to be necessary.



HOUSING + STRAIGHT FEMALE PLUG

R197.114.K01

CRIMP TYPE 5/50S CABLE PACK500

Series : **SMB**
CARLOCK

PACKAGING

Standard	Unit	Other
500	'W' option	Contact us

SPECIFICATION

SAE/USCAR-17 Rev.1 (October 2002)
SAE/USCAR-2 Rev.3 (February 2001)
SAE/USCAR-18 Rev.2 (January 2003)

CABLE ASSEMBLY

ELECTRICAL CHARACTERISTICS

Stripping	a	b	c	d	e	f
mm	2,40	5,50	9,40	0,00	7,00	0,00

Impedance	50	Ω
Frequency	0-4	GHz
VSWR	1.20** + 0,0000	x F(GHz) Maxi
Insertion loss	0.05	\sqrt{F} (GHz) dB Maxi
RF leakage	-45	- F(GHz)) dB Maxi
Voltage rating	335	Veff Maxi
Dielectric withstanding voltage	1000	Veff mini
Insulation resistance	1000	M Ω mini

Assembly instruction : **Page 3**

Recommended cable(s)
RG 58

Characteristics indicated on this data sheet are those that can be achieved with the highest performance cable. Intrinsic limitations of the cable may diminish the performance of the assembly

Cable retention

- pull off **180** N mini
- torque **NA** N.cm

MECHANICAL CHARACTERISTICS

TOOLING

Center contact retention		
Axial force – Mating end	10	N mini
Axial force – Opposite end	10	N mini
Torque	NA	N.cm mini

Part Number	Description	Hexagon
.	.	.
R282.293.000	CRIMPING TOOL M22520/5-01	
R282.235.910	CRIMPING DIES	Square 1.1
R282.235.011	CRIMPING DIES M22520/5-11	Hex 5.41
R282.281.000	CRIMPING TOOL	2x4pts 7pos
R282.967.034	POSITIONER FOR TOOL R282 281	

Recommended torque		
Mating	NA	N.cm
Panel nut	NA	N.cm
Clamp nut	NA	N.cm
A/F clamp nut	0,0000	mm

Mating life	100	Cycles mini
Weight	3,5300	g

OTHERS CHARACTERISTICS

ENVIRONMENTAL

* Depends on the cable used
** VSWR : 1.20 maxi at 4GHz

Operating temperature	-40/+110*	$^{\circ}$ C
Hermetic seal	NA	Atm.cm3/s
Panel leakage	NA	

Issue : **0737 B**

In the effort to improve our products, we reserve the right to make changes judged to be necessary.



HOUSING + STRAIGHT FEMALE PLUG

CRIMP TYPE 5/50S CABLE PACK500

R197.114.K01

Series : SMB
CARLOCK

Recommended mounting procedure for RG58 cable

COMPONENTS

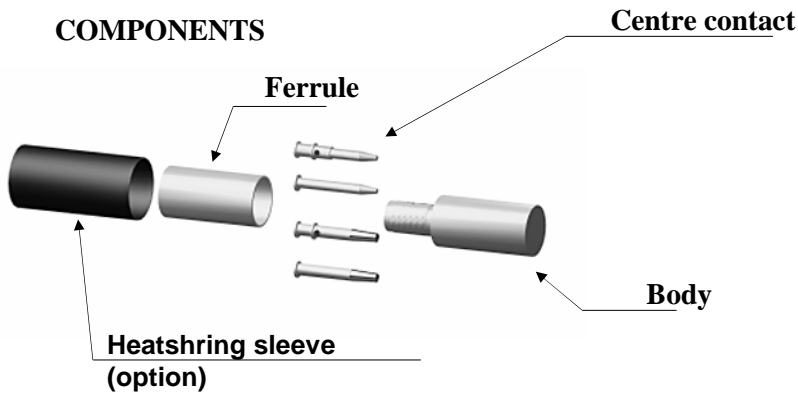

STRIPPING DIMENSIONS

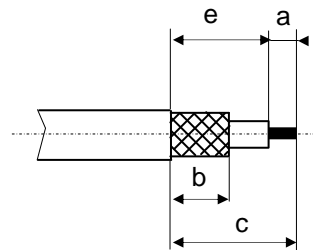

1

Slide the heatshrink sleeve onto the cable (Option).
Slide the ferrule onto the cable.
Strip the cable.



4

Slide the cable into the body until it bottoms against insulator.

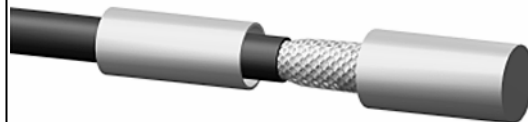

2

Slide the centre contact on until it bottoms against the cable dielectric.
Crimp the centre contact with crimping tool R282.235.910 (square 1.1) or with crimping tool R282.281.000 (7 position 2x4pts) + positioner R282.967.034.



5

Slide the ferrule over the braid.
Crimp the ferrule with crimping tool R282.235.011 (Hex 5.41).

After crimping

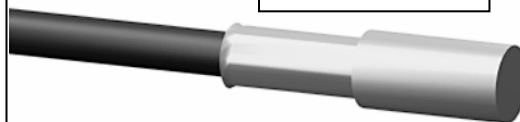

3

Fan the braid.

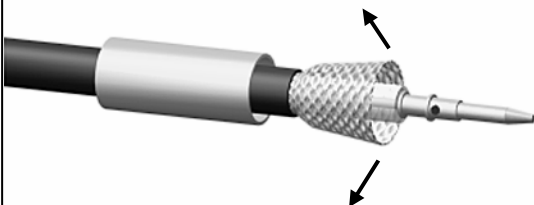

6

Check the position of the centre contact between the top of the center contact and the SMB ref. plane : **0.57 ±0.165**.

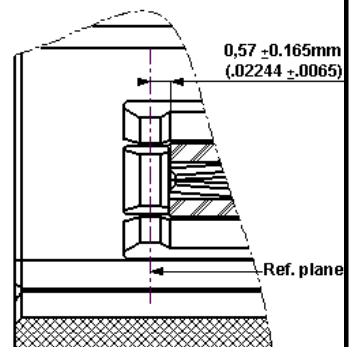

Issue : 0737 B

In the effort to improve our products, we reserve the right to make changes judged to be necessary.



RADIALL®